

---

---

# Universal Shade Cover User Manual

For Six Pole Round or Top Ring (Halo) Trampoline Models



Assembly, Installation, Care, Maintenance,  
and User Instructions



**WARNING**



**READ THESE MATERIALS PRIOR TO ASSEMBLING AND  
USING THIS TRAMPOLINE SHADE COVER**

**Failure to assemble and use this Trampoline Shade Cover as specified in this manual will  
automatically void the warranty.**

Do Not return this product to the store. Instead, please visit our website at [www.PropelTrampolines.com](http://www.PropelTrampolines.com) where you will find our current contact information. Our friendly customer service staff can help you with any problems or questions that may arise during the installation, use, maintenance of your Trampoline Shade Cover.



Read all assembly, care, maintenance, and user instructions in this manual prior to installing and using this Trampoline Shade Cover.

Please save this manual for future reference and check our website for the latest manual revisions.

#### **LIABILITY DISCLAIMER:**

While every attempt is made to embody the highest degree of protection in all equipment, we cannot guarantee freedom from injury. The user assumes all risk of injury due to use, assembly, or transportation. All merchandise is sold on this condition. No representative of the company can waive or change disclaimer condition.

# BEFORE YOU BEGIN

Thank you for purchasing a Propel Universal Shade Cover for your trampoline.

This Universal Shade Cover comes equipped with warnings and instructions for its proper installation, care, maintenance, and use. This information must be read by all supervisors and users before any person is allowed to use it.

Follow all warnings in this manual. If you have any questions regarding these warnings, please contact us.

After reading this manual, if you have further questions, or if you would like to contact us, please visit our website at [www.PropelTrampolines.com](http://www.PropelTrampolines.com).



1. DO NOT jump with Shade Cover
2. Remove Shade Cover before stormy weather or precipitation
3. DO NOT Use flame or heat in or around Shade Cover
4. Use trampoline, trampoline enclosure, and Shade Cover only with mature, knowledgeable supervision.



The Universal Shade Cover will work with most brands of trampolines that have six enclosure poles or Top Ring (Halo) enclosures.

## ASSEMBLY INSTRUCTIONS

### IMPORTANT ASSEMBLY INFORMATION

- This Product is meant to attach to a trampoline that has six enclosure poles for proper assembly.
- You may need special tools to assemble or properly secure your trampoline's enclosure and net combination. See your trampolines owner's manual for proper enclosure installation.

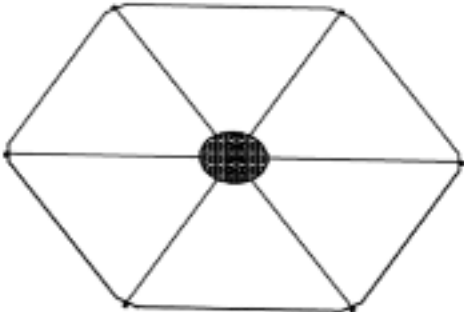
# Parts list

NO	Part Name	Image	Quantity
1	Cover		1
2	Bungee		6



**Step 1** – Make sure that the Enclosure Poles on the Trampoline are secure and will not pull out while attaching the Universal Shade Cover. This may involve using a screwdriver or adjustable wrench to secure the enclosure poles in place (See your trampolines owner’s manual for proper enclosure pole installation).

**1 – Universal Shade Cover.**

**2- Bungee.**

**3- Enclosure Pole.**

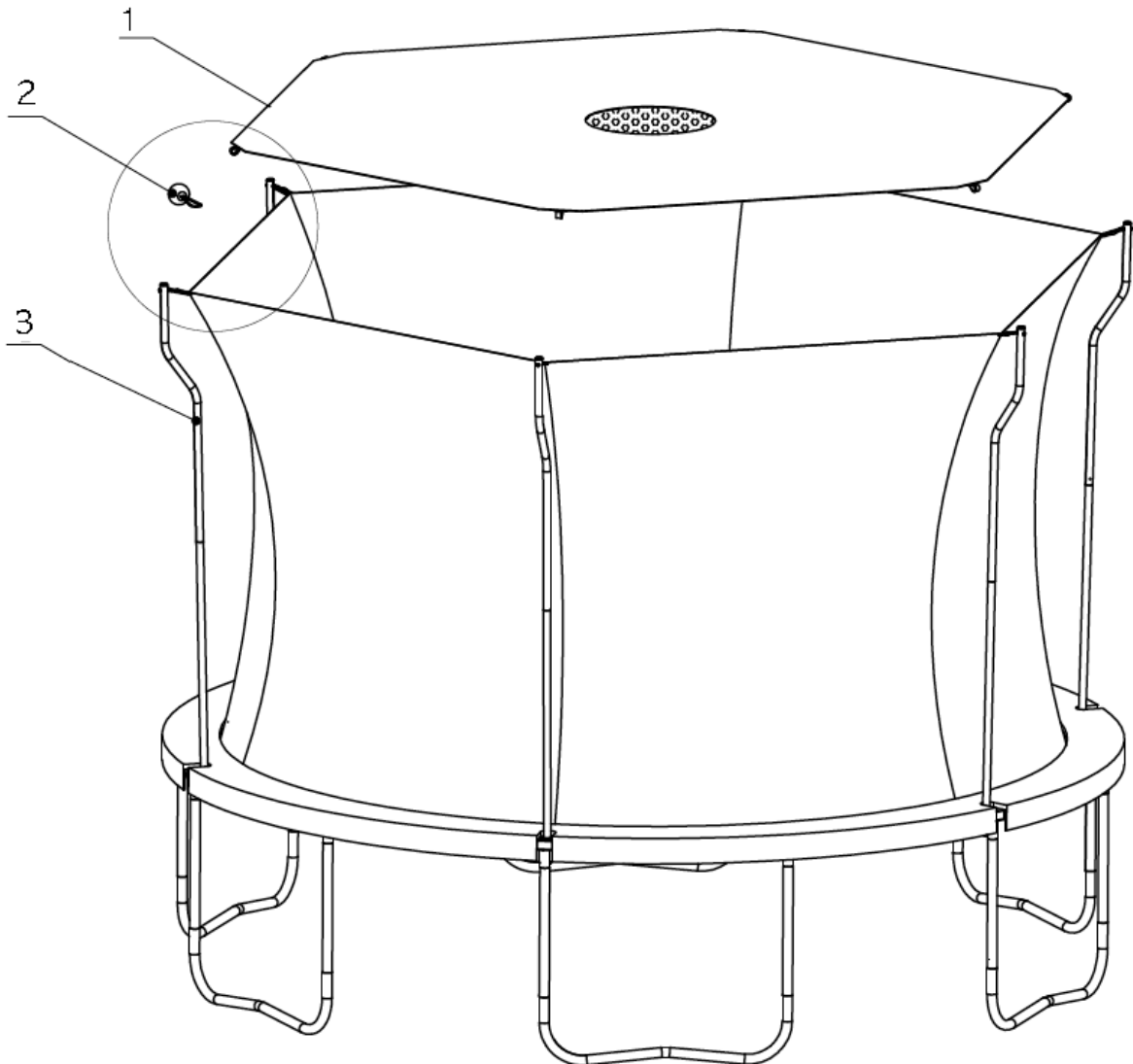

**Step 2** – It is easiest to connect all the bungees to the corners of the Universal Shade Cover before full installation.

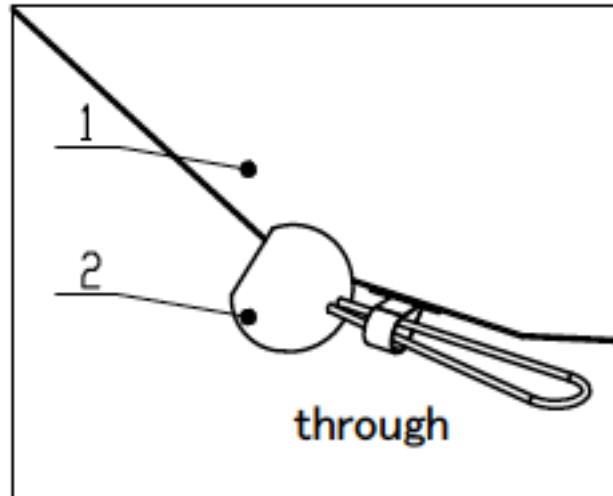

**Step 3** – After all the Bungees have been attached to the Universal Shade Cover. The easiest way to install the Universal Shade Cover is from inside the enclosure on the trampoline.



**Step 4** – To attach each bungee, loop it over the six enclosure poles or to the Top Ring (Halo).

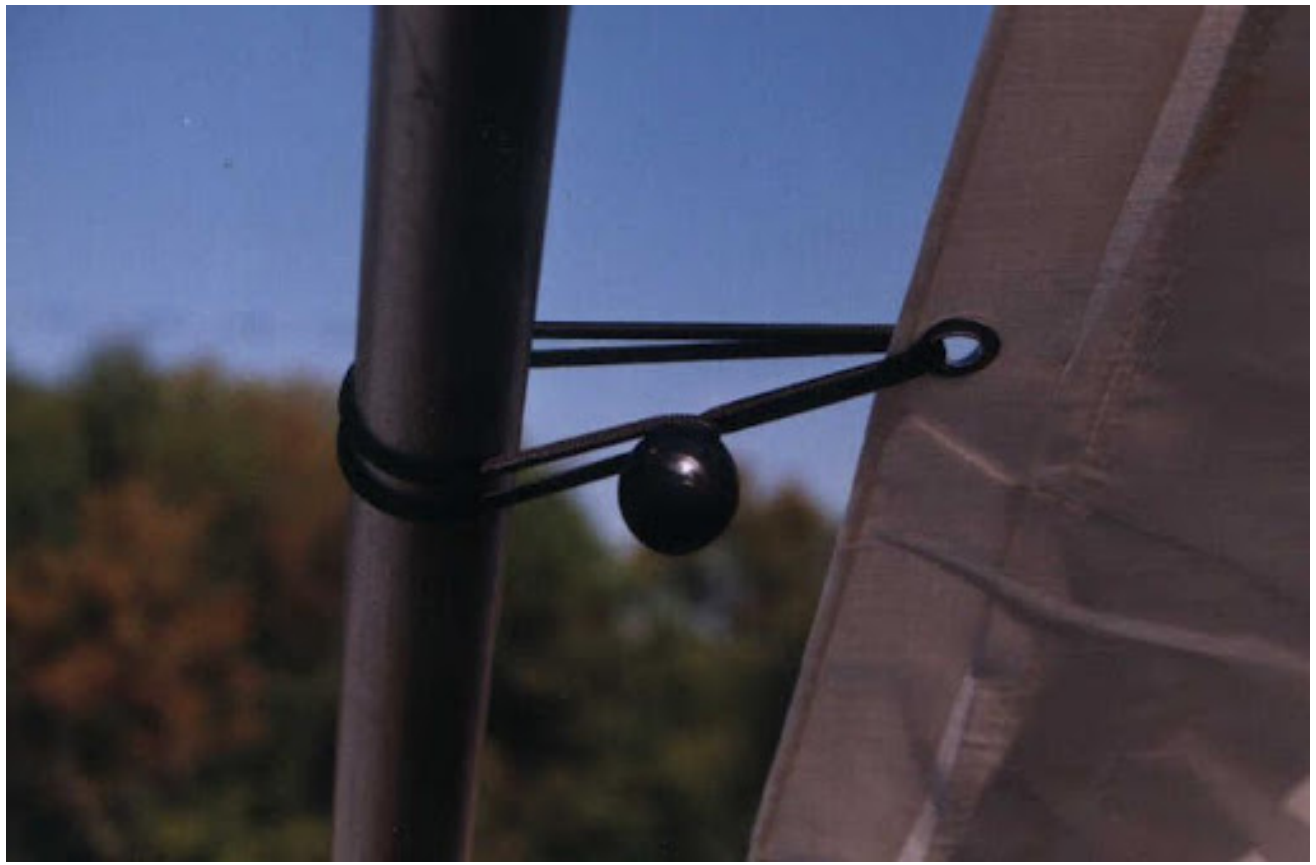
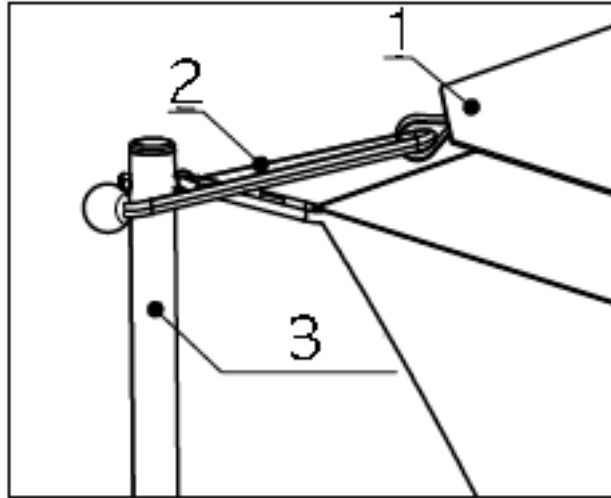







 Make sure that all parts are securely attached. Familiarize yourself and all users of the trampoline Shade Cover with all safety precautions. Read the instructions carefully, and all maintenance materials in this manual and also the original manufactures manual before using the trampoline.

## LIMITED WARRANTY

PROPEL warrants its trampoline products to be free from defects in material and workmanship under normal use and service conditions. The Propel Trampoline Shade Cover accessory is warranted for ninety (90) days from the date of purchase.

All warranty coverage extends only to the original retail purchaser from the original date of purchase. Our obligation under this warranty is limited to replacing or repairing the product at our discretion. All products for which a warranty claim is made must

be received by us at one of our authorized service centers. Freight must be prepaid and accompanied by proof of purchase. All returns must be pre-authorized. This Warranty does not extend to any product, or damage to a product that is caused by or attributable to freight damage, abuse, misuse, improper or abnormal usage, act of God, storm damage, installation or use of accessories, repairs not performed by our authorized service center, and to products used for commercial or rental purposes. No other warranty expressed or implied beyond that specifically set forth above is authorized.

Propel Trampolines is not responsible or liable for indirect, special, or consequential damages arising out of, or in connection with the use or performance of this product. Propel is not responsible for other damages with respect to any economic loss, loss of property, loss of revenue or profits, loss of enjoyment or use, cost of removal or installation, and any other consequential damages. In the United States of America some states do not allow the exclusion or limitation of incidental or consequential damages. Accordingly, the above limitation may not apply to you.

The warranty extended hereunder is in lieu of all other warranties, and any implied warranty of merchantability or fitness for a particular purpose is limited in its scope and duration to the terms set forth herein. In the United States of America some states do not allow limitations on how long an implied warranty lasts. Accordingly, the above limitation may not apply to you.

This warranty gives you specific legal rights. You may also have other rights which vary from state to state in the United States of America.

## **Warranty Registration**

Don't forget to register your trampoline by visiting [www.PropelTrampolines.com/warranty](http://www.PropelTrampolines.com/warranty) . Registering your Trampoline Shade Cover entitles you to receive all warranty benefits.

You may also register your Trampoline Shade Cover by mailing a copy of your sales receipt along with your name, address, phone number and the model number of your trampoline to:

Propel Trampolines  
Warranty Department

41 East 400 North #324  
Logan, UT 84321

**www.propeltrampolines.com**

## **MY TRAMPOLINE INFORMATION**

In the event you need to contact customer service, such as to ask questions, order replacement parts, or file a warranty claim; you will be asked to provide some basic information about your Trampoline and Shade Cover Accessory. By writing this information in the spaces below and keeping this Manual in an accessible location, you can help expedite this process.

Staple or otherwise affix dated sales receipt here.

If it is necessary to file a warranty claim, you will be asked to provide a copy for proof of date of purchase.

— —

**The following information can be found printed on the end of the box in which your Trampoline Shade Cover came.**

Model or Item number: \_\_\_\_\_

MF Code: \_\_\_\_\_

Manufacturing Facility: \_\_\_\_\_